

Technical Data Sheet

WEISS™

FV20

200mm Inline Fan Unit

Boxed

Dimensions

Fan Size

200mm

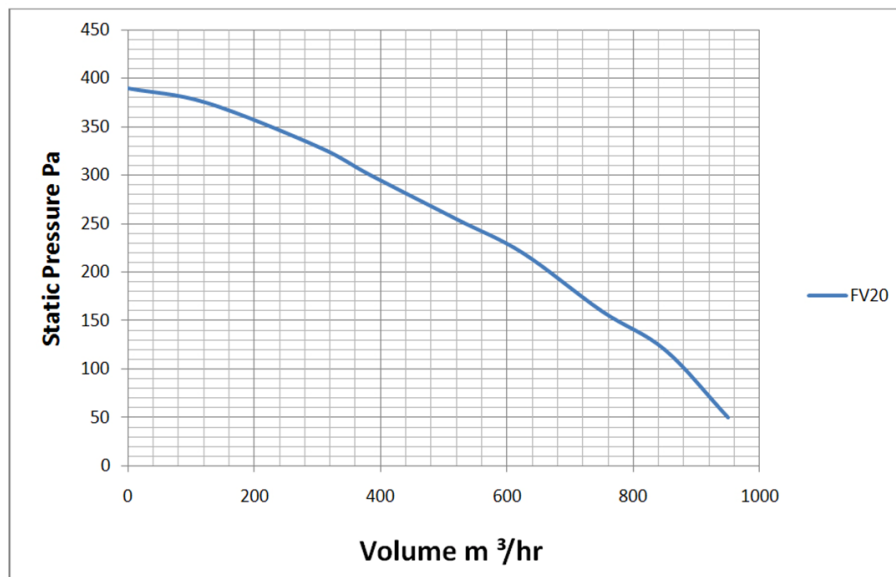
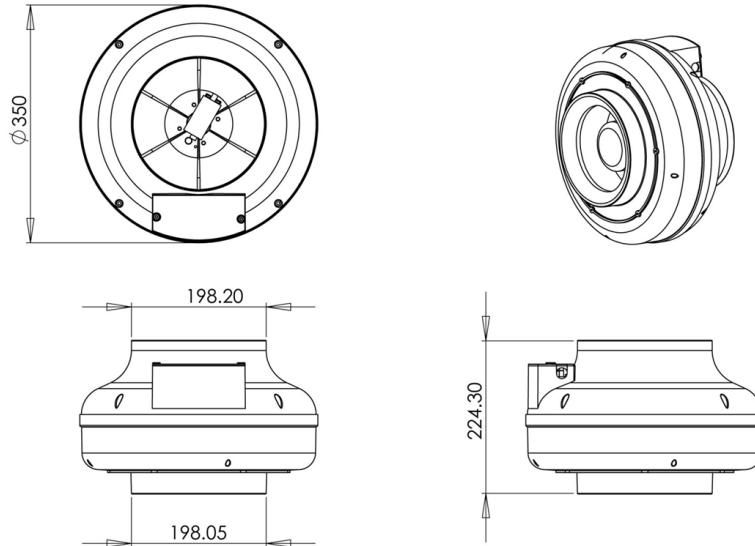

Specifications

N/A

Approval

AS/NZS 3350.2.80:1998 Amdts 1-3 "Electrical Fan"

Features

- Easy to install
- 3 year warranty

Technical Data Sheet

Product Use

The FV20 is used for light commercial installations

Typical applications:

- Toilets
- Motels/Hotels
- Common areas

Environmental Conditions

Operation	to IEC 721-3-3
Climatic conditions	class 3K5
Temperature	0...+50°C
Humidity	<95% r.h.

Standards

Test standards	A/S NZS 3350.2.80:1998 Amdts 1-3 "Electric Fans"
EMC Compliance	This is a Level One product with an external rotor motor that has a very low risk of causing EMC Interference

General

Weight	2.5kg
Colour	Black
Housing Material	Flame Retardant ABS
Inlet Diameter	140mm
Outlet Diameter	200mm

Ordering

When ordering please give name and type,	
Reference	FV20
Barcode	942000490157-7

Technical Data

Power Supply	230 VAC
Power Consumption	max. 0.4 amp
Supply Line Fusing	max. 10A
For Solid Wires	2 x 1.5mm ²
Motor	230-240VAC 50Hz 0.4Amp
Motor Insulation Class	B1
Motor Protection	Impedance Protected
Total Product Wattage	100Watts
Free Air Fan Performance	950m ³ /hr 77.8L/sec
Installed DB rating at 1.5m	-